

MHC KENWORTH

3331 Greig Drive
 Robinson, TX 76706
 254-662-2100

SERVICE ESTIMATE

62

NAME: Lana Chapman
 ADDRESS: _____

 AX #: _____
 PHONE #: _____

DATE: 12/21/2022

INSURANCE CO.: _____
 INS. CO. PHONE #: _____
 ADJUSTERS: _____

LICENSE #:	
UNIT #:	
YEAR:	
MAKE:	
MODEL:	
SERIAL #:	1XP7D49X0BD121311
MILEAGE:	649646
ENGINE MODEL:	
ENGINE SERIAL#:	
TRANS. MODEL:	
TRANS. SERIAL #:	
REAR END MODEL:	
REAR END SERIAL #:	

QUANTITY		WORK TO BE DONE / PART DESCRIPTION	LABOR COST	PARTS EACH	PARTS TOTAL	SUBLET
REPAIR	REPLACE					
1		exhaust leak, found exhaust leak at the manifold where it bolts up.	\$1,600.00			
	1	gasket manifold		\$33.80	\$33.80	
	4	gasket manifold		\$24.35	\$97.40	
	1	turbo gasket		\$31.61	\$31.61	
	4	studs for turbo		\$26.54	\$106.16	
	4	lock nuts for studs		\$13.89	\$55.56	
1		power steering fluid leak, bad cap and gasket	\$300.00			
	1	cap for resivor		\$31.98	\$31.98	
	1	gasket manifold		\$5.85	\$5.85	
1		air leaks on unit, found bad fitting at the firewall	\$200.00			
	1	fitting straight		\$21.49	\$21.49	
	1	fitting H-BARB		\$72.40	\$72.40	
1		no crank no start, batteries dead put charge on and wouldnt hold a charge	\$400.00			
	4	batteries		\$87.99	\$351.96	

As agreed and understood that the above is an estimate only based on visual inspection. Estimate is only good for 90 days. The total estimate figure is subject to change or adjustment due to parts, prices, or incorrect part numbers, and labor is subject to adjustment for any hidden damage or open items. Air freight will be paid by the customer.

All sales and repairs are cash unless prior arrangements have been made by the credit department. Payment is due and payable five working days after completion of the job.

TOTAL LABOR	\$2,500.00
TOTAL PARTS	\$808.21
MISCELLANEOUS	\$300.00
FREIGHT	\$85.00
TOTAL SUBLET REPAIRS	
SALES TAX 8.25%	\$91.43
GRAND TOTAL	\$3,784.64

ASSOCIATED REPAIR ORDER NUMBER:

CCP

Truckworx Kenworth – Tuscaloosa, LLC

3933 Reese Phifer Ave
Tuscaloosa, AL 35401
Phone: (205) 526-2160
Fax: (205) 526-2161

***** Customer Review *****
Date / Time: 10/13/2022 4:55:58PM
Repair Order: 106276
Customer: 00011
Branch: TUS
Invoice Total: \$30,037.23

COD
Page 3 of 3

Bill To: Hamilton Pipe Company
3933 Kauloosa Ave
HAMILTON, TX 35401

Ship To: Hamilton Pipe Company

HAMILTON, TX 35401

Fax: 205-526-2161

Customer P/O: codyp

Completion Date:

Payment Method

COD

Totals	
Total Parts:	\$18,797.36
Total Core Chg:	\$312.50
Total Core Ret:	\$0.00
Total EHC:	\$0.00
Total Labor:	\$8,750.00
Total Miscellaneous:	\$275.00
Invoice Subtotal:	\$28,134.86
Total Tax:	\$1,902.37
Invoiced Total:	\$30,037.23

Truckworx Kenworth – Tuscaloosa, LLC

3933 Reese Phifer Ave
 Tuscaloosa, AL 35401
 Phone: (205) 526-2160
 Fax: (205) 526-2161

***** Customer Review *****

Date / Time: 10/13/2022 4:55:58PM
 Repair Order: 106276
 Customer: 00011
 Branch: TUS
 Invoice Total: \$30,037.23

COD
 Page 2 of 3

Bill To: Hamilton Pipe Company
 3933 Kauloosa Ave
 HAMILTON, TX 35401

Ship To: Hamilton Pipe Company
 HAMILTON, TX 35401

Fax: 205-526-2161

Customer P/O:	codyp					Completion Date:		
CX	3687007CUM	SEAL,RECTANGULAR STRIP	Part	EA	1.00	46.69	44.39	44.39
CX	3688113CUM	PLUG,GEAR COVER	Part	EA	1.00	15.07	14.32	14.32
CX	3690567CUM	PAN,OIL	Part	EA	1.00	1,934.66	1,839.29	1,839.29
CX	4026684CUM	GASKET,OIL PAN	Part	EA	1.00	257.87	245.16	245.16
CX	4101451CUM	SCREW,CAPTIVE WASHER CAP	Part	EA	3.00	3.52	3.35	10.05
CX	4299124CUM	SEAL,O RING	Part	EA	1.00	13.26	12.61	12.61
CX	4299125CUM	SEAL,O RING	Part	EA	1.00	17.52	16.66	16.66
CX	4374074CUM	SCREW,TWELVE POINT CAP	Part	EA	3.00	2.43	2.31	6.93
CX	4393089CUM	GASKET,GEAR HOUSING	Part	EA	1.00	83.45	79.34	79.34
KP	4520PEN	CLEANER -NON-CHLORINATED BRK HIGH V.O.C.	Part	EA	36.00	3.71	2.75	99.00
CX	5414049CUM	GASKET,FUEL PUMP	Part	EA	1.00	29.35	27.90	27.90
CX	5468170CUM	HOUSING,GEAR	Part	EA	1.00	960.13	912.80	912.80
CX	5484100CUM	SHAFT,IDLER	Part	EA	1.00	100.86	95.89	95.89
INL	CT05317	TIE-CABLE 50LB 15.5" BLK	Part	EA	30.00	0.15	0.13	3.90
AS	EC3501	COOLANT-TRP ELC 50/50 JUG	Part	EA	3.00	8.98	7.99	23.97
FG	LF14000NNFLG	FILTER	Part	EA	1.00	76.70	76.70	76.70
ATR	MM55-62002HTATR	MOTOR MOUNT KIT (REAR) (HIGH TEMP)	Part	EA	2.00	113.32	106.66	213.32
FRN	R134ACBXW	R134a 1lb for shop	Part	EA	4.00	27.64	25.96	103.84
TRO	TE10W30G	10W30 HEAVY DUTY ENGINE OIL 3/1 GA JUGS	Part	EA	13.00	26.99	25.85	336.05
CX	4298628CUM	CAMSHAFT	Part	EA	1.00	2,530.21	2,405.48	2,405.48
CX	5658294CUM	HEAD,CYLINDER	Part	EA	1.00	8,311.08	7,901.37	7,901.37
CX	5484230CUM	LEVER,ROCKER	Part	EA	1.00	151.13	143.68	143.68
CX	5579417PXCUM	KIT, INJECTOR	Part	EA	1.00	1,343.03	1,249.33	1,249.33
CX	5579417PXCUM-C	INJECTOR-XPI	Inherent		1.00	312.50	312.50	312.50
CX	4352360CUM	KIT,EXH RCN COOLER	Part	EA	1.00	2,351.09	2,235.20	2,235.20
CX	4921517CUM	SENSOR,PRESSURE	Part	EA	1.00	108.45	103.10	103.10
CX	2880215CUM	GASKET, AFM DEVICE	Part	EA	1.00	20.29	19.29	19.29
CX	2866337CUM	GASKET, AFM DEVICE	Part	EA	1.00	15.62	14.85	14.85

Truckworx Kenworth - Tuscaloosa, LLC

3933 Reese Phifer Ave
 Tuscaloosa, AL 35401
 Phone: (205) 526-2160
 Fax: (205) 526-2161

Put in TRK folder

***** Customer Review *****
 Date / Time: 10/13/2022 4:55:58PM
 Repair Order: 106276
 Customer: 00011
 Branch: TUS
 Invoice Total: \$30,037.23
 COD
 Page 1 of 3

Bill To: Hamilton Pipe Company
 3933 Kauloosa Ave
 HAMILTON, TX 35401

Ship To: Hamilton Pipe Company
 HAMILTON, TX 35401

Fax: 205-526-2161

Customer P/O: codyp Completion Date: _____

Unit Number: 121311 Model Year: 2011 Make/Model: Peterbilt 387
 Type: Service Truck VIN: 1XP7D49X0BD121311 Meter: 643812 Miles
 ECM Reading: 17814

TSX 15
N-14

Task: 1 047-000002 Cummins Engine Diagnostics Department: Service
Complaint: CEL ON

Correction: MUST GET ECM DOWNLOAD! CASE#: _____
 HOOKED INSIDE TO TRUCK AND HAD FIVE ACTIVE CODES,01111-ENGINE OIL PRESSURE,0125-INTAKE MANIFOLD PRESSURE,1655-MISSFIRE CYLINDER 2,3318-AFTERTREATMENT INTAKE TEMP,5383-AFTERTREATMENT ASHLOAD.1655 FIRST STEP WAS TO TEST INJECTORS,BUT WOULD NOT RUN.NEXT WAS TO PULL VALVE COVER OFF TO INSPECT CAM SHAFT.FOUND NUMBER TWO INTAKE ROCKER WITH PITTING ON ROLLER AND CAM LOBE WITH PITTING,ALSO FOUND VALVE BRIDGE LAYING IN THE HEAD.COULD POSSIBLE HAVE A BENT VALVE,ALSO FOUND FRONT STRUCTURE LEAKING.REMOVED EGR CROSSOVER PIPE AND WAS WET INSIDE.TOOK PIPE ON REAR OF EGR COOLER OFF AND FOUND COOLANT.EGR COOLER IS RUPTURED.

Supp.	Part	Description / Ref Number	U/M	Quantity	List Price	Extended Price
	Comp Fee	Computer Fee	Misc	1.00	0.00	25.00
	Shop Suppl	Shop Supplies	Misc	1.00	0.00	250.00
CE	3081695	SEAL,O RING	Part	EA	4.63	4.25
CE	3163075	PAINT RED	Part	EA	27.15	24.93
CE	3823258	PAD, CLEANING	Part	EA	2.97	2.73
CE	3823718	609 LOCTITE	Part	EA	56.57	51.95
CE	4954442	SEAL,O RING	Part	EA	4.87	4.47
KL	07485	3M ROLOC DISC	Part	EA	5.39	4.68
NAP	07526	MMM 3" GREEN ROLOC DISC	Part	EA	18.89	17.75
LUC	105FBC	GREASE-MOTOR ASSY 10 OZ L0034-094	Part	EA	9.09	8.79
MXE	1905795PE	TIE STRAP	Part	EA	3.25	2.96
INT	2614861C92	A/C ORING KIT	Part	EA	86.18	80.91
CX	3068935CUM	DOWEL,PIN	Part	EA	11.32	10.76
CX	3104392CUM	GASKET,VALVE COVER	Part	EA	67.93	64.58
CX	3164067CUM	SEALANT	Part	EA	25.97	24.69
CX	3678756CUM	SEAL,O RING	Part	EA	10.17	9.67
CX	3679932CUM	GASKET,CAMSHAFT COVER	Part	EA	10.96	10.42
CX	3680882CUM	SCREW,CAPTIVE WASHER CAP	Part	EA	7.48	7.11
CX	3685173CUM	SEAL,OIL	Part	EA	75.06	71.36
CX	3685556CUM	GASKET,ADAPTER	Part	EA	13.86	13.18
CX	5440813CUM	GASKET,ACC DRIVE SUPPORT	Part	EA	17.30	16.44
CX	3685701CUM	SEAL,O RING	Part	EA	11.42	10.85
CX	3686368CUM	SEAL,RECTANGULAR RING	Part	EA	13.19	12.54



TRUCKWORX

Truckworx Kenworth - Tuscaloosa, LLC
 3933 Reese Phifer Ave
 Tuscaloosa, AL 35401
 Office: (205) 526-2160
 Fax: (205) 526-2161

INVOICE DATE	
11/9/2022 10:42:45AM	
INVOICE NO.	PAGE
1140106276	1
CUSTOMER NO.	BRANCH
00011	TUS

Sold To:
 Hamilton Pipe Company
 3933 Kauloosa Ave
 HAMILTON, TX 35401

Ship To:
 Hamilton Pipe Company
 HAMILTON, TX 35401

Customer P.O.	R/S Order No.	Phone#	Counterman
	106276	(254) 784-0369	900/House
		Price Per	Extension

Completion Date: 11/07/2022

Unit Number: 121311

Model Year: 2011

Make/Model: Peterbilt 387

Type: Service Truck

VIN: 1XP7D49X0BD121311

Meter: 643812 Miles

Task: 1 047-000002 Cummins Engine Diagnostics

Department: Service

Complaint: CEL ON

Correction: MUST GET ECM DOWNLOAD! CASE#: _____
 HOOKED INSITE TO TRUCK AND HAD FIVE ACTIVE CODES,01111-ENGINE OIL PRESSURE,0125-INTAKE MANIFOLD PRESSURE,1655-MISSFIRE CYLINDER 2,3318-AFTERTREATMENT INTAKE TEMP,5383-AFTERTREATMENT ASHLOAD.1655 FIRST STEP WAS TO TEST INJECTORS,BUT WOULD NOT RUN.NEXT WAS TO PULL VALVE COVER OFF TO INSPECT CAM SHAFT.FOUND NUMBER TWO INTAKE ROCKER WITH PITTING ON ROLLER AND CAM LOBE WITH PITTING,ALSO FOUND VALVE BRIDGE LAYING IN THE HEAD.COULD POSSIBLE HAVE A BENT VALVE,ALSO FOUND FRONT STRUCTURE LEAKING.REMOVED EGR CROSSOVER PIPE AND WAS WET INSIDE.TOOK PIPE ON REAR OF EGR COOLER OFF AND FOUND COOLANT.EGR COOLER IS RUPTURED....REMOVED RADIATOR, CLIMATE BOX, AIR BOX AND INTAKE PIPING. VALVE COVER, ROCKER ARMS, TIMING COMPONETS, OIL PAN, OIL PUMP, HEAD, MEASURED LINERS AND THE LINERS WERE OUT OF SPEC. PULLED PISTONS AND RODS THEN OLD LINERS, COUNTER BOARD BLOCK. USED NEW SHIMS TO GET CORRECT LINER HEIGHT. INSTALLED NEW LINERS SHIMS AND O-RINGS. ASSEMBLED NEW PISTONS ON OLD RODS, NEW RINGS, INSTALLED PISTON RODS INTO LINERS, INSTALLED NEW ROD BEARINGS, TORQUED TO SPEC, REPLACED ALL MAIN BEARINGS THEN TORQUED CAPS TO SPEC. REINSTALLED OIL PUMP, STRENGTH PLATE THEN OIL PAN. INSTALLED HEAD, USED NEW HEAD BOLTS THEN TORQUED TO SPEC, REPLACED INTAKE ROCKERS, INSTALLED ROCKER ASSEMBLIES, INSTALLED 1 NEW INJECTOR, TIMED ENGINE, REPLACED FRONT STRUCTURE AND GASKET. FILLED WITH OIL THEN STARTED TRUCK. INSTALLED ALL ACCESS PARTS. FILLED WITH COOLANT. LET TRUCK RUN TO CHECK FOR LEAKS, NO ISSUE TASK COMPLETE.

V/C	Part	Description / Ref Number	U/M	Quantity	Extended Price
KL	07485	3M ROLOC DISC	EA	1.00	\$4.68
NAP	07526	MMM 3" GREEN ROLOC DISC	EA	1.00	\$17.75
LUC	105FBC	GREASE-MOTOR ASSY 10 OZ L0034-094	EA	1.00	\$8.79
INT	2614861C92	A/C ORING KIT	EA	1.00	\$80.91
CX	2866337CUM	GASKET, AFM DEVICE	EA	1.00	\$14.85
	Warranty repairs and claims must be performed by an authorized Cummins dealer . No over the counter warranty claims .				
CX	3068935CUM	DOWEL_PIN	EA	2.00	\$21.52
	Warranty repairs and claims must be performed by an authorized Cummins dealer . No over the counter warranty claims .				
CE	3081695	SEAL,O RING	EA	1.00	\$4.25
CE	3163075	PAINT RED	EA	1.00	\$24.93
CX	3164067CUM	SEALANT	EA	1.00	\$24.69
	Warranty repairs and claims must be performed by an authorized Cummins dealer . No over the counter warranty claims .				
CX	3678506CUM	SCREW,HEX FLANGE HEAD CAP	EA	22.00	\$423.72
	Warranty repairs and claims must be performed by an authorized Cummins dealer . No over the counter warranty claims .				
CX	3678804CUM	SCREW,HEX FLANGE HEAD CAP	EA	4.00	\$62.20
	Warranty repairs and claims must be performed by an authorized Cummins dealer . No over the counter warranty claims .				

Freight	Sub Total	Tax Status/State	Sales Tax	1.00 Please	\$10.42

CONTINUED

All returns (warranty or credit) must be accompanied by this invoice and will only be accepted between 8:00 a.m. and 5:00 p.m. Monday through Friday. All returns are subject to a restocking charge. All returns must be made within 7 days to receive full credit. Non-stock special order parts are not returnable. This transaction is governed by the terms and conditions on reverse side.

X
 CUSTOMER COPY



TRUCKWORX

Truckworx Kenworth - Tuscaloosa, LLC
 3933 Reese Phifer Ave
 Tuscaloosa, AL 35401
 Office: (205) 526-2160
 Fax: (205) 526-2161

INVOICE DATE	
11/9/2022	10:42:45AM
INVOICE NO.	PAGE
1140106276	3
CUSTOMER NO.	BRANCH
00011	TUS

Sold To:

Hamilton Pipe Company
 3933 Kauloosa Ave
 HAMILTON, TX 35401

Ship To:

Hamilton Pipe Company
 HAMILTON, TX 35401

Customer P.O.	R/S Order No.	Phone#	Counterman
	106276	(254) 784-0369	900/House
		Price Per	Extension

CX	5468170CUM	HOUSING,GEAR	EA	1.00	\$737.00
	Warranty repairs and claims must be performed by an authorized Cummins dealer . No over the counter warranty claims .				
CX	5484100CUM	SHAFT,IDLER	EA	1.00	\$95.89
	Warranty repairs and claims must be performed by an authorized Cummins dealer . No over the counter warranty claims .				
CX	5484230CUM	LEVER,ROCKER	EA	3.00	\$300.00
	Warranty repairs and claims must be performed by an authorized Cummins dealer . No over the counter warranty claims .				
CX	5579417PXCUM	KIT, INJECTOR	EA	1.00	\$1,093.17
	Warranty repairs and claims must be performed by an authorized Cummins dealer . No over the counter warranty claims .				
	All Cummins Recon parts warranties must be repair by an authorized Cummins dealer no over the counter warranties .				
CX	5579417PXCUM-C	INJECTOR-XPI	EA	1.00	\$312.50
	Warranty repairs and claims must be performed by an authorized Cummins dealer . No over the counter warranty claims .				
CX	5579417PXCUM-C	INJECTOR-XPI	EA	-1.00	(\$312.50)
	Warranty repairs and claims must be performed by an authorized Cummins dealer . No over the counter warranty claims .				
CX	5579451CUM	KIT, CLASSIC OVERHAUL	EA	1.00	\$6,408.50
	Warranty repairs and claims must be performed by an authorized Cummins dealer . No over the counter warranty claims .				
CX	5594275NXCUM	SENSOR, POSITION	EA	1.00	\$33.52
	Warranty repairs and claims must be performed by an authorized Cummins dealer . No over the counter warranty claims .				
	All Cummins Recon parts warranties must be repair by an authorized Cummins dealer no over the counter warranties .				
CX	5594275NXCUM-C	SENSOR, POSITION-Core	EA	1.00	\$12.50
	Warranty repairs and claims must be performed by an authorized Cummins dealer . No over the counter warranty claims .				
CX	5594275NXCUM-C	SENSOR, POSITION-Core	EA	-1.00	(\$12.50)
	Warranty repairs and claims must be performed by an authorized Cummins dealer . No over the counter warranty claims .				
CX	5658175CUM	SEAL, RECTANGULAR RING	EA	1.00	\$11.93
	ship ups!!!!				
	Warranty repairs and claims must be performed by an authorized Cummins dealer . No over the counter warranty claims .				
CX	5658294CUM	HEAD,CYLINDER	EA	1.00	\$6,379.63
	Warranty repairs and claims must be performed by an authorized Cummins dealer . No over the counter warranty claims .				
INL	CT05317	TIE-CABLE 50LB 15.5" BLK	EA	30.00	\$3.90
AS	EC3501	COOLANT-TRP ELC 50/50 JUG	EA	3.00	\$23.97
LNJ	HWC04916	NUT-HEX SL NYL M20-2.50X22.15T CL10 CAD	EA	2.00	\$10.60
FRN	R134ACBXW	R134a 1lb for shop	EA	4.00	\$103.84
TRO	TE10W30G	10W30 HEAVY DUTY ENGINE OIL 3/1 GA JUGS	EA	13.00	\$336.05
	Comp Fee	Computer Fee		1.00	\$25.00
	PIA	Paid in Advance		-1.00	(\$15,000.00)
	Shop Suppl	Shop Supplies		1.00	\$250.00

Task 1 Subtotals

Parts:	\$21,936.42
Core Chg:	\$325.00
Core Ret:	(\$325.00)
Labor:	\$12,250.00
Miscellaneous:	(\$14,725.00)
Task 1 Subtotals:	\$19,461.42

Freight	Sub Total	Tax Status/State	Total Parts Sales Tax	\$21,936.42 Please Pay

****CONTINUED****

All returns (warranty or credit) must be accompanied by this invoice and will only be accepted between 8:00 a.m. and 5:00 p.m. Monday through Friday. All returns are subject to a restocking charge. All returns must be made within 7 days to receive full credit. Non-stock special order parts are not returnable. This transaction is governed by the terms and conditions on reverse side.

X _____
CUSTOMER COPY



TRUCKWORX

Truckworx Kenworth - Tuscaloosa, LLC

3933 Reese Phifer Ave

Tuscaloosa, AL 35401

Office: (205) 526-2160

Fax: (205) 526-2161

INVOICE DATE

11/9/2022 10:42:45AM

INVOICE NO. PAGE

1140106276 2

CUSTOMER NO. BRANCH

00011 TUS

Sold To:

Hamilton Pipe Company
3933 Kauloosa Ave
HAMILTON, TX 35401

Ship To:

Hamilton Pipe Company
HAMILTON, TX 35401

Customer P.O.	R/S Order No.	Phone#	Counterman
	106276	(254) 784-0369	900/House
		Price Per	Extension

CX	3680882CUM	Warranty repairs and claims must be performed by an authorized Cummins dealer . No over the counter warranty claims . SCREW,CAPTIVE WASHER CAP	EA	12.00	\$85.32
CX	3683940CUM	Warranty repairs and claims must be performed by an authorized Cummins dealer . No over the counter warranty claims . SEAL,EXHAUST MANIFOLD	EA	2.00	\$105.94
CX	3685173CUM	Warranty repairs and claims must be performed by an authorized Cummins dealer . No over the counter warranty claims . SEAL,OIL	EA	1.00	\$71.36
CX	3685556CUM	Warranty repairs and claims must be performed by an authorized Cummins dealer . No over the counter warranty claims . GASKET,ADAPTER	EA	1.00	\$13.18
CX	3685701CUM	Warranty repairs and claims must be performed by an authorized Cummins dealer . No over the counter warranty claims . SEAL,O RING	EA	1.00	\$10.85
CX	3686838CUM	Warranty repairs and claims must be performed by an authorized Cummins dealer . No over the counter warranty claims . CLAMP-T BOLT	EA	1.00	\$24.91
CX	3687007CUM	Warranty repairs and claims must be performed by an authorized Cummins dealer . No over the counter warranty claims . SEAL,RECTANGULAR STRIP	EA	1.00	\$44.39
CX	3688113CUM	Warranty repairs and claims must be performed by an authorized Cummins dealer . No over the counter warranty claims . PLUG,GEAR COVER	EA	1.00	\$14.32
CX	3689251CUM	Warranty repairs and claims must be performed by an authorized Cummins dealer . No over the counter warranty claims . MANIFOLD-EXHAUST	EA	1.00	\$810.57
CE	3823258	Warranty repairs and claims must be performed by an authorized Cummins dealer . No over the counter warranty claims . PAD, CLEANING	EA	1.00	\$2.73
CE	3823718	609 LOCTITE	EA	1.00	\$51.95
CX	4298628CUM	Warranty repairs and claims must be performed by an authorized Cummins dealer . No over the counter warranty claims . CAMSHAFT	EA	1.00	\$1,942.21
CX	4299124CUM	Warranty repairs and claims must be performed by an authorized Cummins dealer . No over the counter warranty claims . SEAL,O RING	EA	1.00	\$12.61
CX	4299125CUM	Warranty repairs and claims must be performed by an authorized Cummins dealer . No over the counter warranty claims . SEAL,O RING	EA	1.00	\$16.66
CX	4352360CUM	Warranty repairs and claims must be performed by an authorized Cummins dealer . No over the counter warranty claims . KIT,EXH RCN COOLER	EA	1.00	\$1,804.71
CX	4374074CUM	Warranty repairs and claims must be performed by an authorized Cummins dealer . No over the counter warranty claims . SCREW,TWELVE POINT CAP	EA	3.00	\$6.93
CX	4393089CUM	Warranty repairs and claims must be performed by an authorized Cummins dealer . No over the counter warranty claims . GASKET,GEAR HOUSING	EA	1.00	\$79.34
KP	4520PEN	CLEANER -NON-CHLORINATED BRK HIGH V.O.	EA	36.00	\$99.00
CX	4921517CUM	Warranty repairs and claims must be performed by an authorized Cummins dealer . No over the counter warranty claims . SENSOR,PRESSURE	EA	1.00	\$103.10
CE	4954442	SEAL,O RING	EA	1.00	\$4.47
CX	5298564CUM	Warranty repairs and claims must be performed by an authorized Cummins dealer . No over the counter warranty claims . SHIM	EA	6.00	\$350.82
CX	5414049CUM	Warranty repairs and claims must be performed by an authorized Cummins dealer . No over the counter warranty claims . GASKET,FUEL PUMP	EA	1.00	\$27.90
CX	5440813CUM	Warranty repairs and claims must be performed by an authorized Cummins dealer . No over the counter warranty claims . GASKET,ACC DRIVE SUPPORT	EA	1.00	\$16.44

Freight	Sub Total	Tax Status/State	Sales Tax	Please Pay
				CONTINUED

All returns (warranty or credit) must be accompanied by this invoice and will only be accepted between 8:00 a.m. and 5:00 p.m. Monday through Friday. All returns are subject to a restocking charge. All returns must be made within 7 days to receive full credit. Non-stock special order parts are not returnable. This transaction is governed by the terms and conditions on reverse side.

X

CUSTOMER COPY



TRUCKWORX

Truckworx Kenworth - Tuscaloosa, LLC
 3933 Reese Phifer Ave
 Tuscaloosa, AL 35401
 Office: (205) 526-2160
 Fax: (205) 526-2161

INVOICE DATE	
11/9/2022 10:42:45AM	
INVOICE NO.	PAGE
1140106276	4
CUSTOMER NO.	BRANCH
00011	TUS

Sold To:

Hamilton Pipe Company
 3933 Kauloosa Ave
 HAMILTON, TX 35401

Ship To:

Hamilton Pipe Company
 HAMILTON, TX 35401

Customer P.O.	R/S Order No.	Phone#	Counterman
	106276	(254) 784-0369	900/House
		Price Per	Extension

Total Core Chg:	\$325.00
Total Core Ret:	(\$325.00)
Total Labor:	\$12,250.00
Total Miscellaneous:	(\$14,725.00)
Invoice Subtotal:	\$19,461.42
Total Tax:	\$2,185.03
Invoiced Total:	\$21,646.45

Payment Method
 COD

<input type="checkbox"/> Cash	<input type="checkbox"/> Visa	<input type="checkbox"/> M/C	<input type="checkbox"/> Disc	<input type="checkbox"/> Amex	Check: <input type="checkbox"/> Personal <input type="checkbox"/> Company <input type="checkbox"/> Other: _____	Check #: _____
Cardholder: _____		Drivers License #: _____		State: _____		
Card #: _____		Exp: _____				
Paid By: _____		Drivers License #: _____		State: _____		
Date: _____		Manager Approval: _____		Cashier: _____		

Freight	Sub Total	Tax Status/State	Sales Tax	Please Pay
	19,461.42	Taxable AL	2,185.03	21,646.45
				COD

All returns (warranty or credit) must be accompanied by this invoice and will only be accepted between 8:00 a.m. and 5:00 p.m. Monday through Friday. All returns are subject to a restocking charge. All returns must be made within 7 days to receive full credit. Non-stock special order parts are not returnable. This transaction is governed by the terms and conditions on reverse side.

X _____
 CUSTOMER COPY

+ 15,060

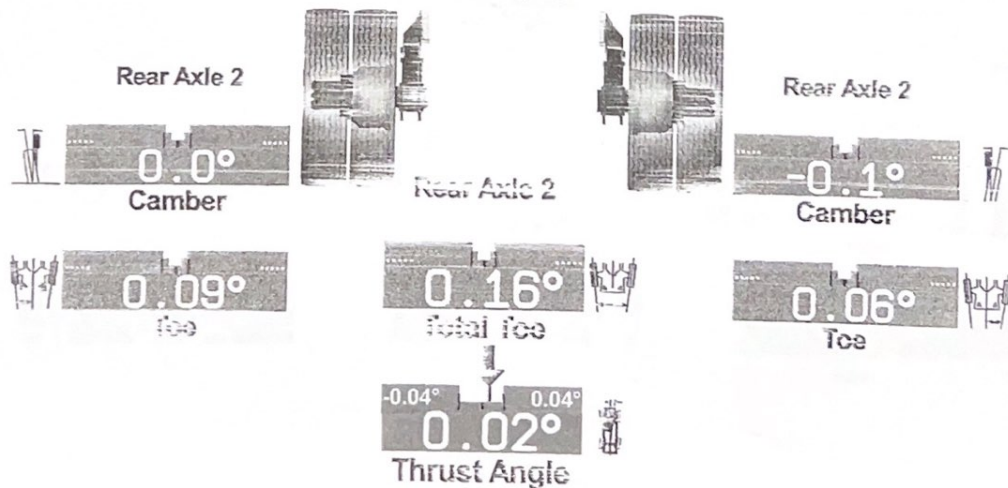
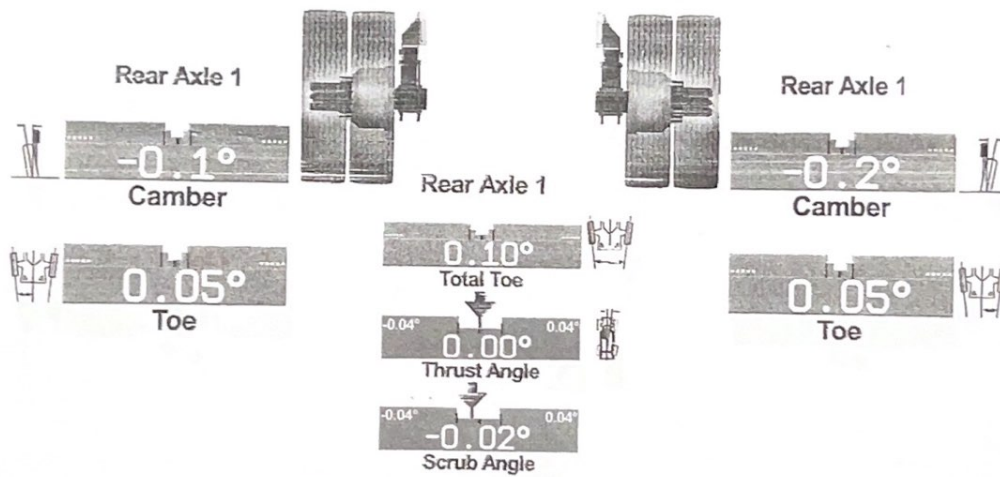
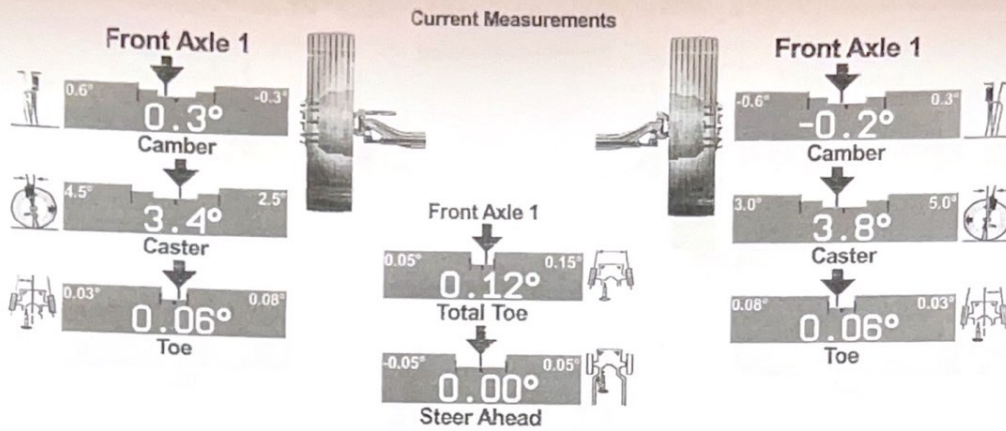

• One or more values are not within specification. Tire wear, handling and safety problems may result

2022 8:52 AM

Odometer: 638551

201 1132974

Heavy Duty Vehicles : Peterbilt : Eaton/Spicer Axles : E12021 : 12000lb Axle Load, with Power Assisted Steering : with Leaf Spring
 Total Alignment Without Caster on Rear Axles, 6 sensors

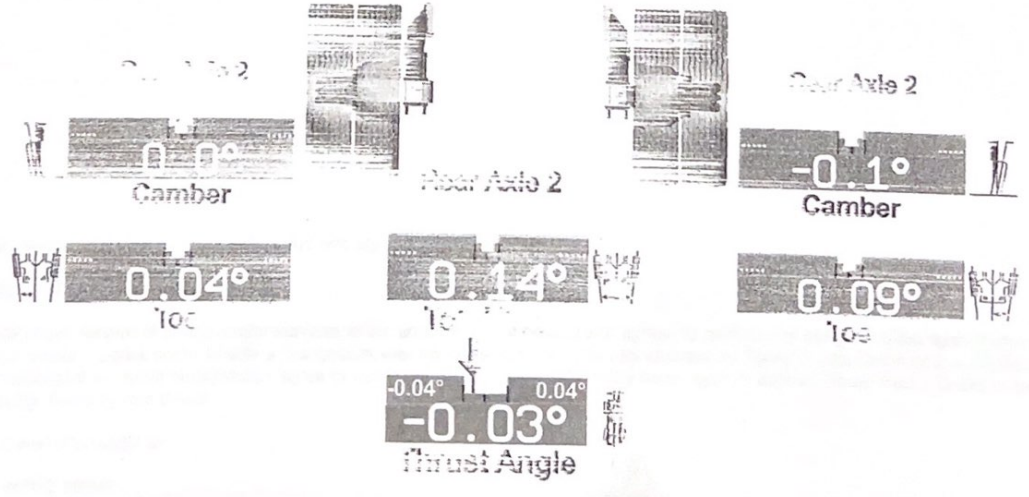
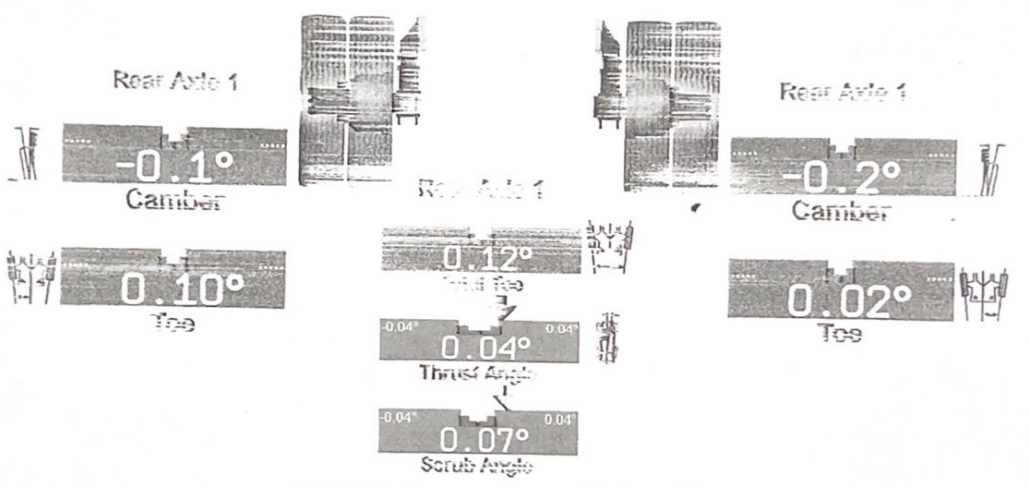
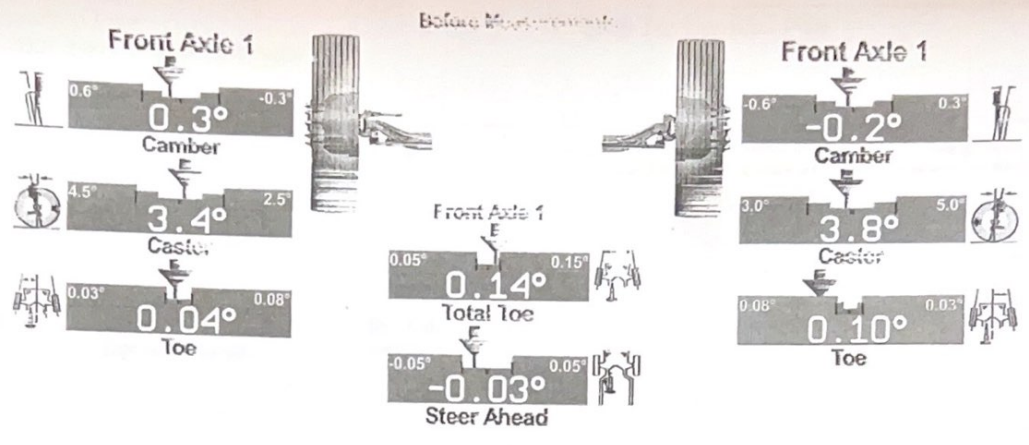



875 East South Loop
 P.O. Box 1947
 Stephenville, TX 76401
 Ph: (254) 965-4403
 www.txtrucksdirect.com

**** Reprint ****
 Invoice: **01S119078**
 Date / Hour: 8/22/2022 11:18:03AM
 Repair Order: 119078
 Customer: 1725
 Branch: 01
 Total Invoice: \$ 1,979.07
 Check - 40551
 Page 3 of 3

Bill To: Hamilton Pipe
 Thank You For Your Business!
 Come Back Again!
 Stephenville, TX 76401

Ship To: Hamilton Pipe
 , TX

Customer P/O: mbishop Karmak ' Orig R/O: 0 Completion Date: 8/20/2022

Invoice Subtotal:	\$1,922.94
Total Tax:	\$56.13
Total Invoice:	\$1,979.07

Payment Method	Terms	Due Date
Check	Due Upon Receipt	8/22/2022

By signing above you state you have read, understood and agreed with the below:

Customers Paying By Credit Card:

Consumer acknowledges receipt of goods and/or services in the amount shown hereon and agrees to perform the obligations set forth by the cardmember's agreement with the issuer. I agree not to initiate a chargeback with my credit card company for charges by Texas Trucks Direct and understand that any such chargebacks will constitute a breach of contract. I agree to waive any chargeback rights I may have, and will contact Texas Trucks Direct to resolve any dispute regarding charges by Texas Trucks Direct.

ABOVE REPAIRS AUTHORIZED BY:

CUSTOMER PRINTED NAME: _____



875 East South Loop
P.O. Box 1947
Stephenville, TX 76401
Ph: (254) 965-4403
www.txtrucksdirect.com

**** Reprint ****

Invoice: **01S119078**
Date / Hour: 8/22/2022 11:18:03AM
Repair Order: 119078
Customer: 1725
Branch: 01
Total Invoice: \$ 1,979.07
Check - 40551

Page 2 of 3

Bill To: Hamilton Pipe
Thank You For Your Business!
Come Back Again!
Stephenville, TX 76401

Ship To: Hamilton Pipe
, TX

Customer P/O: mbishop Karmak Orig R/O: 0 Completion Date: 8/20/2022

Correction: 8/19/2022 2:25:36 PM 320 I removed the tires and pulled the old drum off. The drum was cracked and I looked over the brakes and they were still good. I put the new drum on and put the tires back on.

Supp.	Part	Description / Ref Number	U/M	Quantity	Price	Extended Price
	56864B	Brake Drum (Webb)	Each	1.0	\$230.55	\$230.55
	Shop	Shop Supplies		1.0	\$8.75	\$8.75
				Task 5 Subtotals	Parts:	\$230.55
					Labor:	\$125.00
					Miscellaneous:	\$8.75
				Task 5 Subtotals		\$364.30

Task: 6 005 R & R Carrier Bearing Department: Service

Complaint: Replace carrier bearing
Correction: 8/19/2022 4:57:54 PM 201 R&R carrier bearing. I had to remove drive line, remove yoke nut, remove carrier bearing bolts, and remove carrier bearing. I installed the new carrier bearing, installed yoke, and made sure yoke was clocked right. I installed the new yoke nut and tightened to spec. I installed the new carrier bearing nuts and tightened to spec. I installed the drive line and tightened the new strap kit.

Supp.	Part	Description / Ref Number	U/M	Quantity	Price	Extended Price
	10094142	Carrier Bearing	Each	1.0	\$121.46	\$121.46
	250-70-18X	Strap Kit	Each	1.0	\$21.17	\$21.17
	250-74-11	Yoke Nut	Each	1.0	\$29.82	\$29.82
	423085P	Bolt (1/2" x 1-1/2" USS)	Each	2.0	\$1.17	\$2.34
	423204P	Flat Washer (1/2" USS)	Each	2.0	\$0.48	\$0.96
	423259P	Flange Locknut w/ Nylon Insert (1/2" USS)	Each	2.0	\$0.91	\$1.82
	424204P	Flat Washer (1/2" SAE)	Each	2.0	\$0.26	\$0.52
	Shop	Shop Supplies		1.0	\$17.50	\$17.50
				Task 6 Subtotals	Parts:	\$178.09
					Labor:	\$250.00
					Miscellaneous:	\$17.50
				Task 6 Subtotals		\$445.59

Task: 7 004 Alignment 3 axle Department: Service

Complaint: Align
Correction: 8/20/2022 9:45:48 AM 201 3 axle alignment

Supp.	Part	Description / Ref Number	U/M	Quantity	Price	Extended Price
	Shop	Shop Supplies		1.0	\$23.10	\$23.10
				Task 7 Subtotals	Parts:	\$0.00
					Labor:	\$330.00
					Miscellaneous:	\$23.10
				Task 7 Subtotals		\$353.10

Detail Tax Info:
Sales Tax \$56.13
Total: \$56.13

Total Parts: \$680.34
Total Labor: \$1,142.51
Total Miscellaneous: \$100.09



875 East South Loop
 P.O. Box 1947
 Stephenville, TX 76401
 Ph: (254) 965-4403
 www.txtrucksdirect.com

**** Reprint ****
 Invoice: **01S119078**
 Date / Hour: 8/22/2022 11:18:03AM
 Repair Order: 119078
 Customer: 1725
 Branch: 01
 Total Invoice: \$ 1,979.07
 Check - 40551
 Page 1 of 3

Bill To: Hamilton Pipe
 Thank You For Your Business!
 Come Back Again!
 Stephenville, TX 76401

Ship To: Hamilton Pipe
 , TX

Customer P/O: mbishop Karmak Orig R/O: 0 Completion Date: 08/20/2022

Unit Number: 121311 **Model Year:** 2011 **Make/Model:** Peterbilt 379
Type: service **VIN:** 1XP7D49X0BD121311 **Meter:** 638551 Miles

Task: 1 009 Pre-Repair Inspection Department: Service
 Complaint: inspect and advice
 Correction: 8/18/2022 2:25:49 PM 201 pre repair inspection see pre repair sheet

Supp.	Part	Description / Ref Number	U/M	Quantity	Price	Extended Price
Task 1 Subtotals						(S0.01)

Task: 2 010 Test Drive Department: Service
 Complaint: advice

Supp.	Part	Description / Ref Number	U/M	Quantity	Price	Extended Price
Task 2 Subtotals						Parts: \$0.00
						Labor: \$62.50
Task 2 Subtotals						\$62.50

Task: 3 006 Prealignment Inspection Department: Service
 Complaint: front end alignment, has a shimmy around 40/45mph.
 Correction: 8/18/2022 2:47:38 PM 201 Pre alignment inspection:

The only things I found bad are the torque arms over the top of rear differentials.
 The kingpins were good.
 The shackle pins and bushings are good.
 The tie rod ends are good and the drag link is good,
 The rear suspension bushings are good; other than the two torque arms.

Supp.	Part	Description / Ref Number	U/M	Quantity	Price	Extended Price
Shop		Shop Supplies		1.0	\$8.75	\$8.75
Task 3 Subtotals						Parts: \$0.00
						Labor: \$125.00
						Miscellaneous: \$8.75
Task 3 Subtotals						\$133.75

Task: 4 049 R & R Torque Arm Department: Service
 Complaint: Replace 2 torque arm
 Correction: 8/20/2022 8:20:54 AM 201 R&R both torque arms over the top of differentials

Supp.	Part	Description / Ref Number	U/M	Quantity	Price	Extended Price
	83-6029-3	Nylon Tie (15-1/4" Black)	Each	6.0	\$0.21	\$1.26
	TMR553	Torque Rod (Peterbilt)	Each	2.0	\$135.22	\$270.44
	Freight	Freight		1.0	\$24.50	\$24.50
	Shop	Shop Supplies		1.0	\$17.50	\$17.50
Task 4 Subtotals						Parts: \$271.70
						Labor: \$250.00
						Miscellaneous: \$42.00
Task 4 Subtotals						\$563.70

Task: 5 013 R & R Brake Drum (Rear Outboard, Each) Department: Service
 Complaint: Left rear brake drum replace

** See Last Page for Invoice Total **

Truckworx Kenworth – Tuscaloosa, LLC

3933 Reese Phifer Ave
 Tuscaloosa, AL 35401
 Phone: (205) 526-2160
 Fax: (205) 526-2161

***** Customer Review *****
 Date / Time: 11/3/2022 12:43:38PM
 Repair Order: 106276
 Customer: 00011
 Branch: TUS
 Invoice Total: \$24,292.42
 COD
 Page 3 of 3

Bill To: Hamilton Pipe Company
 3933 Kauloosa Ave
 HAMILTON, TX 35401

Ship To: Hamilton Pipe Company
 HAMILTON, TX 35401

Fax: 205-526-2161

Customer P/O: codyp

Completion Date:

Payment Method
 COD

Totals	
Total Parts:	\$24,016.85
Total Core Chg:	\$325.00
Total Core Ret:	\$0.00
Total EHC:	\$0.00
Total Labor:	\$12,250.00
Total Miscellaneous:	(\$14,725.00)
Invoice Subtotal:	\$21,866.85
Total Tax:	\$2,425.57
Invoiced Total:	\$24,292.42

Truckworx Kenworth – Tuscaloosa, LLC

3933 Reese Phifer Ave
 Tuscaloosa, AL 35401
 Phone: (205) 526-2160
 Fax: (205) 526-2161

***** Customer Review *****

Date / Time: 11/3/2022 12:43:38PM
 Repair Order: 106276
 Customer: 00011
 Branch: TUS
 Invoice Total: \$24,292.42

COD

Page 2 of 3

Bill To: Hamilton Pipe Company
 3933 Kauloosa Ave
 HAMILTON, TX 35401

Ship To: Hamilton Pipe Company
 HAMILTON, TX 35401

Fax: 205-526-2161

Customer P/O:	codyp					Completion Date:		
CX	3688113CUM	PLUG,GEAR COVER	Part	EA	1.00	15.07	14.32	14.32
CX	4026684CUM	GASKET,OIL PAN	Part	EA	1.00	257.87	197.94	197.94
CX	4101451CUM	SCREW,CAPTIVE WASHER CAP	Part	EA	3.00	3.52	3.35	10.05
CX	4299124CUM	SEAL,O RING	Part	EA	1.00	13.26	12.61	12.61
CX	4299125CUM	SEAL,O RING	Part	EA	1.00	17.52	16.66	16.66
CX	4374074CUM	SCREW,TWELVE POINT CAP	Part	EA	3.00	2.43	2.31	6.93
CX	4393089CUM	GASKET,GEAR HOUSING	Part	EA	1.00	83.45	79.34	79.34
KP	4520PEN	CLEANER -NON-CHLORINATED	Part	EA	36.00	3.71	2.75	99.00
		BRK HIGH V.O.C.						
CX	5414049CUM	GASKET,FUEL PUMP	Part	EA	1.00	29.35	27.90	27.90
CX	5468170CUM	HOUSING,GEAR	Part	EA	1.00	960.13	737.00	737.00
CX	5484100CUM	SHAFT,IDLER	Part	EA	1.00	100.86	95.89	95.89
INL	CT05317	TIE-CABLE 50LB 15.5" BLK	Part	EA	30.00	0.15	0.13	3.90
AS	EC3501	COOLANT-TRP ELC 50/50 JUG	Part	EA	3.00	8.98	7.99	23.97
FG	LF14000NNFLG	FILTER	Part	EA	1.00	76.70	76.70	76.70
FRN	R134ACBXW	R134a 1lb for shop	Part	EA	4.00	27.64	25.96	103.84
TRO	TE10W30G	10W30 HEAVY DUTY ENGINE OIL	Part	EA	13.00	26.99	25.85	336.05
		3/1 GA JUGS						
CX	4298628CUM	CAMSHAFT	Part	EA	1.00	2,530.21	1,942.21	1,942.21
CX	5658294CUM	HEAD,CYLINDER	Part	EA	1.00	8,311.08	6,379.63	6,379.63
CX	5579417PXCUM	KIT, INJECTOR	Part	EA	1.00	1,343.03	1,093.17	1,093.17
CX	5579417PXCUM-C	INJECTOR-XPI	Inherent		1.00	312.50	312.50	312.50
CX	4352360CUM	KIT,EXH RCN COOLER	Part	EA	1.00	2,351.09	1,804.71	1,804.71
CX	4921517CUM	SENSOR,PRESSURE	Part	EA	1.00	108.45	103.10	103.10
CX	2880215CUM	GASKET, AFM DEVICE	Part	EA	1.00	20.29	19.29	19.29
CX	2866337CUM	GASKET, AFM DEVICE	Part	EA	1.00	15.62	14.85	14.85
	PIA	Paid in Advance	Misc		(1.00)	0.00	15,000.00	(15,000.00)
CX	5298564CUM	SHIM	Part	EA	6.00	61.50	58.47	350.82
CX	3678804CUM	SCREW,HEX FLANGE HEAD CAP	Part	EA	4.00	16.36	15.55	62.20
CX	3678506CUM	SCREW,HEX FLANGE HEAD CAP	Part	EA	22.00	25.09	19.26	423.72
CX	5484230CUM	LEVER,ROCKER	Part	EA	3.00	151.13	100.00	300.00
CX	5658175CUM	SEAL, RECTANGULAR RING	Part	EA	1.00	12.55	11.93	11.93
		ship ups!!!!						
CX	5579451CUM	KIT, CLASSIC OVERHAUL	Part	EA	1.00	8,348.69	7,937.14	7,937.14
CX	4089405CUM	SET,ROD BEARING (STD)	Part	EA	1.00	90.33	85.87	85.87
LNJ	HWC04916	NUT-HEX SL NYL	Part	EA	2.00	5.78	5.30	10.60
		M20-2.50X22.15T CL10 CAD						
CX	5594275NXCUM	SENSOR, POSITION	Part	EA	1.00	35.26	33.52	33.52
CX	5594275NXCUM-C	SENSOR, POSITION-Core	Inherent		1.00	12.50	12.50	12.50
CX	3689251CUM	MANIFOLD-EXHAUST	Part	EA	1.00	852.60	810.57	810.57
CX	3683940CUM	SEAL,EXHAUST MANIFOLD	Part	EA	2.00	55.72	52.97	105.94
CX	3687058CUM	NOZZLE,PISTON COOLING	Part	EA	3.00	31.79	30.23	90.69

Truckworx Kenworth - Tuscaloosa, LLC

3933 Reese Phifer Ave
Tuscaloosa, AL 35401
Phone: (205) 526-2160
Fax: (205) 526-2161

*** Customer Review ***
Date / Time: 11/3/2022 12:43:38PM
Repair Order: 106276
Customer: 00011
Branch: TUS
Invoice Total: \$24,292.42
COD
Page 1 of 3

Bill To: Hamilton Pipe Company
3933 Kauloosa Ave
HAMILTON, TX 35401

Ship To: Hamilton Pipe Company
HAMILTON, TX 35401

Fax: 205-526-2161

Customer P/O: codyp Completion Date:

Unit Number: 121311 Model Year: 2011 Make/Model: Peterbilt 387
Type: Service Truck VIN: 1XP7D49X0BD121311 Meter: 643812 Miles
ECM Reading: 17814

Task: 1 047-000002 Cummins Engine Diagnostics Department: Service
Complaint: CEL ON

Correction: MUST GET ECM DOWNLOAD! CASE#: _____
HOOKED INSITE TO TRUCK AND HAD FIVE ACTIVE CODES,01111-ENGINE OIL PRESSURE,0125-INTAKE MANIFOLD PRESSURE,1655-MISSFIRE CYLINDER 2,3318-AFTERTREATMENT INTAKE TEMP,5383-AFTERTREATMENT ASHLOAD,1655 FIRST STEP WAS TO TEST INJECTORS,BUT WOULD NOT RUN.NEXT WAS TO PULL VALVE COVER OFF TO INSPECT CAM SHAFT.FOUND NUMBER TWO INTAKE ROCKER WITH PITTING ON ROLLER AND CAM LOBE WITH PITTING,ALSO FOUND VALVE BRIDGE LAYING IN THE HEAD.COULD POSSIBLE HAVE A BENT VALVE,ALSO FOUND FRONT STRUCTURE LEAKING.REMOVED EGR CROSSOVER PIPE AND WAS WET INSIDE.TOOK PIPE ON REAR OF EGR COOLER OFF AND FOUND COOLANT.EGR COOLER IS RUPTURED.

Supp.	Part	Description / Ref Number	U/M	Quantity	List	Price	Extended Price
	Comp Fee	Computer Fee	Misc	1.00	0.00	25.00	25.00
	Shop Suppl	Shop Supplies	Misc	1.00	0.00	250.00	250.00
CE	3081695	SEAL,O RING	Part	EA	1.00	4.63	4.25
CE	3163075	PAINT RED	Part	EA	1.00	27.15	24.93
CE	3823258	PAD, CLEANING	Part	EA	1.00	2.97	2.73
CE	3823718	609 LOCTITE	Part	EA	1.00	56.57	51.95
CE	4954442	SEAL,O RING	Part	EA	1.00	4.87	4.47
KL	07485	3M ROLOC DISC	Part	EA	1.00	5.39	4.68
NAP	07526	MMM 3" GREEN ROLOC DISC	Part	EA	1.00	18.89	17.75
LUC	105FBC	GREASE-MOTOR ASSY 10 OZ L0034-094	Part	EA	1.00	9.09	8.79
MXE	1905795PE	TIE STRAP	Part	EA	5.00	3.25	2.96
INT	2614861C92	A/C ORING KIT	Part	EA	1.00	86.18	80.91
CX	3068935CUM	DOWEL,PIN	Part	EA	2.00	11.32	10.76
CX	3104392CUM	GASKET,VALVE COVER	Part	EA	1.00	67.93	64.58
CX	3164067CUM	SEALANT	Part	EA	1.00	25.97	24.69
CX	3678756CUM	SEAL,O RING	Part	EA	1.00	10.17	9.67
CX	3679932CUM	GASKET,CAMSHAFT COVER	Part	EA	1.00	10.96	10.42
CX	3680882CUM	SCREW,CAPTIVE WASHER CAP	Part	EA	13.00	7.48	7.11
CX	3685173CUM	SEAL,OIL	Part	EA	1.00	75.06	71.36
CX	3685556CUM	GASKET,ADAPTER	Part	EA	1.00	13.86	13.18
CX	5440813CUM	GASKET,ACC DRIVE SUPPORT	Part	EA	1.00	17.30	16.44
CX	3685701CUM	SEAL,O RING	Part	EA	1.00	11.42	10.85
CX	3687007CUM	SEAL,RECTANGULAR STRIP	Part	EA	1.00	46.69	44.39

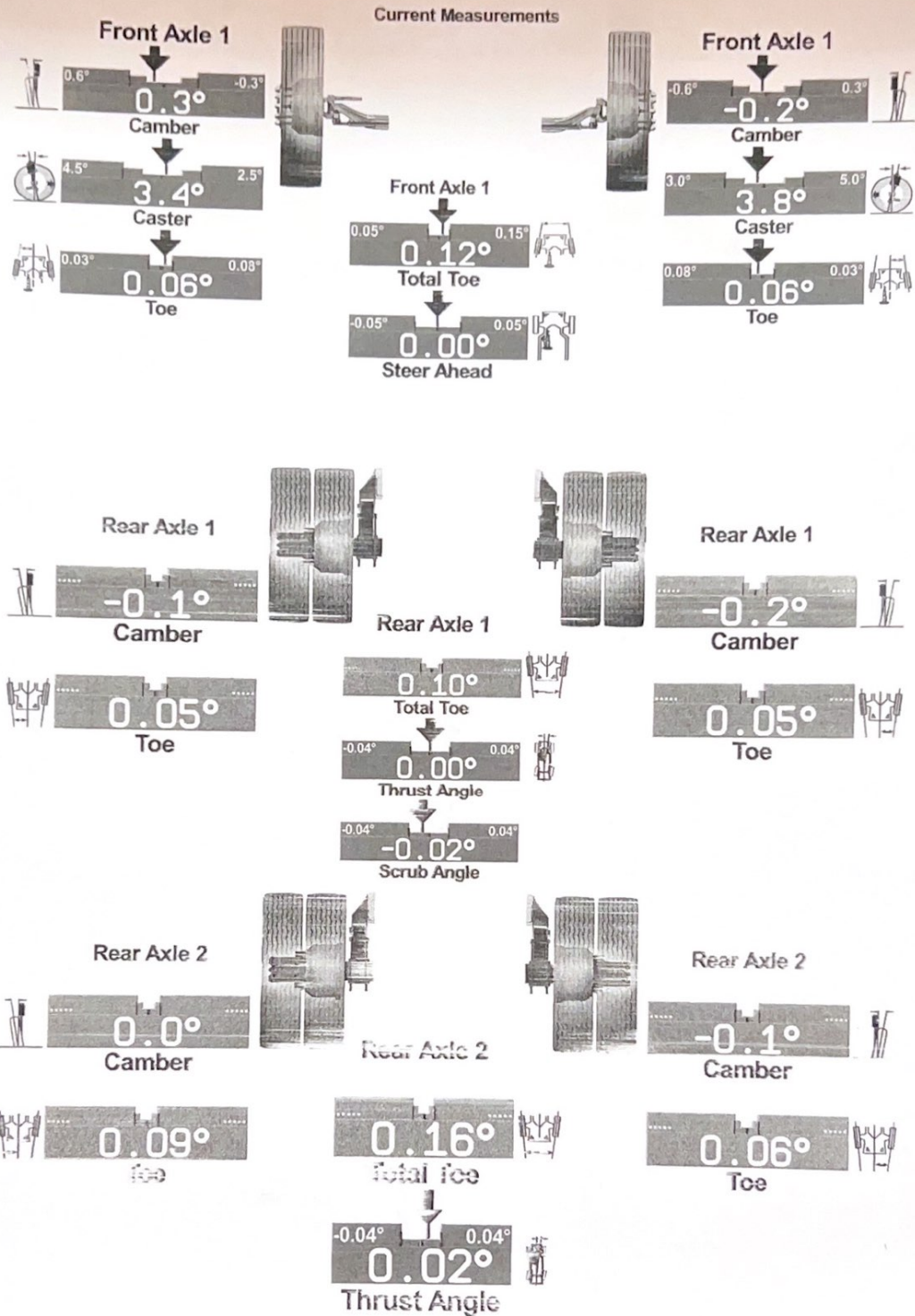

• One or more values are not within specification. Tire wear, handling and safety problems may result.

119016
8/20/22 8:52 AM
pice
201 1132974

Ordometer:638551

Heavy Duty Vehicles : Peterbilt : Eaton/Spicer Axles : E12021 : 12000lb Axle Load, with Power Assisted Steering : with Leaf Spring
Total Alignment Without Caster on Rear Axles, 6 sensors

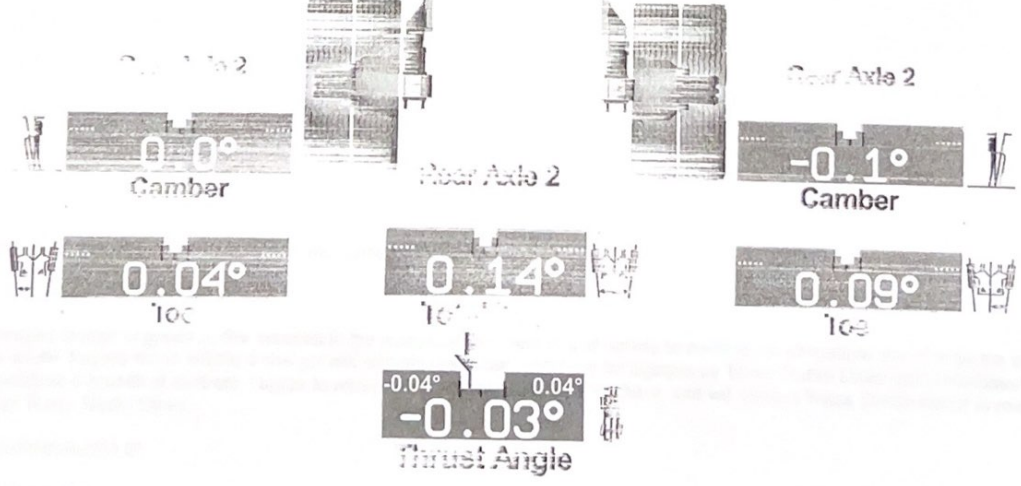
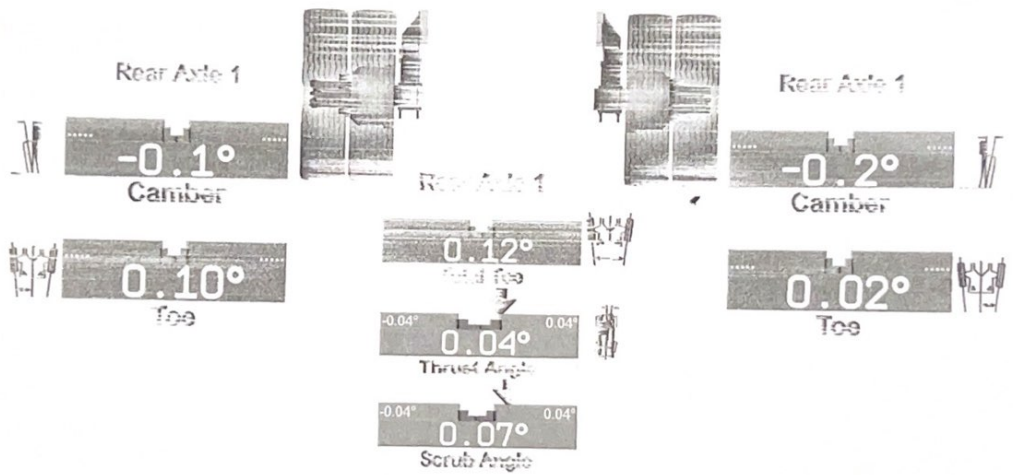
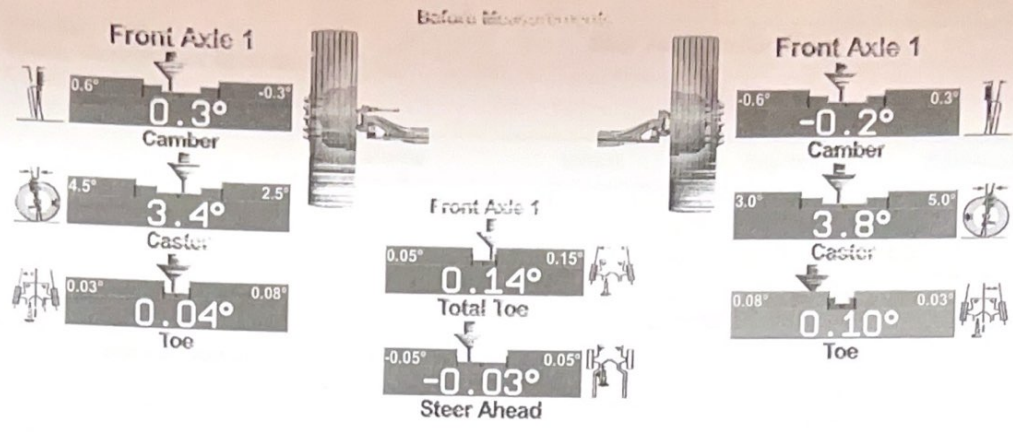



875 East South Loop
 P.O. Box 1947
 Stephenville, TX 76401
 Ph: (254) 965-4403
 www.txtrucksdirect.com

**** Reprint ****
 Invoice: **01S119078**
 Date / Hour: 8/22/2022 11:18:03AM
 Repair Order: 119078
 Customer: 1725
 Branch: 01
 Total Invoice: \$ 1,979.07
 Check - 40551
 Page 3 of 3

Bill To: Hamilton Pipe
 Thank You For Your Business!
 Come Back Again!
 Stephenville, TX 76401

Ship To: Hamilton Pipe
 , TX

Customer P/O: mbishop Karmak Orig R/O: 0 Completion Date: 8/20/2022

Invoice Subtotal:	\$1,922.94
Total Tax:	\$56.13
Total Invoice:	\$1,979.07

<u>Payment Method</u>	<u>Terms</u>	<u>Due Date</u>
Check	Due Upon Receipt	8/22/2022

By signing above you state you have read, understood and agreed with the below:

Customers Paying By Credit Card:

Consumer acknowledges receipt of goods and/or services in the amount shown hereon and agrees to perform the obligations set forth by the cardmember's agreement with the issuer. I agree not to initiate a chargeback with my credit card company for charges by Texas Trucks Direct and understand that any such chargebacks will constitute a breach of contract. I agree to waive any chargeback rights I may have, and will contact Texas Trucks Direct to resolve any dispute regarding charges by Texas Trucks Direct.

ABOVE REPAIRS AUTHORIZED BY:

CUSTOMER PRINTED NAME: _____



875 East South Loop
 P.O. Box 1947
 Stephenville, TX 76401
 Ph: (254) 965-4403
 www.txtrucksdirect.com

**** Reprint ****
 Invoice: **01S119078**
 Date / Hour: 8/22/2022 11:18:03AM
 Repair Order: 119078
 Customer: 1725
 Branch: 01
 Total Invoice: \$ 1,979.07
 Check - 40551
 Page 2 of 3

Bill To: Hamilton Pipe
 Thank You For Your Business!
 Come Back Again!
 Stephenville, TX 76401

Ship To: Hamilton Pipe
 , TX

Customer P/O: mbishop Karmak Orig R/O: 0 Completion Date: 8/20/2022

Correction: 8/19/2022 2:25:36 PM 320 I removed the tires and pulled the old drum off. The drum was cracked and I looked over the brakes and they were still good. I put the new drum on and put the tires back on.

Supp. Part	Description / Ref Number	U/M	Quantity	Price	Extended Price
56864B	Brake Drum (Webb)	Each	1.0	\$230.55	\$230.55
Shop	Shop Supplies		1.0	\$8.75	\$8.75
Task 5 Subtotals				Parts:	\$230.55
				Labor:	\$125.00
				Miscellaneous:	\$8.75
				Task 5 Subtotals	\$364.30

Task: 6 005 R & R Carrier Bearing Department: Service

Complaint: Replace carrier bearing
 Correction: 8/19/2022 4:57:54 PM 201 R&R carrier bearing. I had to remove drive line, remove yoke nut, remove carrier bearing bolts, and remove carrier bearing. I installed the new carrier bearing, installed yoke, and made sure yoke was clocked right. I installed the new yoke nut and tightened to spec. I installed the new carrier bearing nuts and tightened to spec. I installed the drive line and tightened the new strap kit.

Supp. Part	Description / Ref Number	U/M	Quantity	Price	Extended Price
10094142	Carrier Bearing	Each	1.0	\$121.46	\$121.46
250-70-18X	Strap Kit	Each	1.0	\$21.17	\$21.17
250-74-11	Yoke Nut	Each	1.0	\$29.82	\$29.82
423085P	Bolt (1/2" x 1-1/2" USS)	Each	2.0	\$1.17	\$2.34
423204P	Flat Washer (1/2" USS)	Each	2.0	\$0.48	\$0.96
423259P	Flange Locknut w/ Nylon Insert (1/2" USS)	Each	2.0	\$0.91	\$1.82
424204P	Flat Washer (1/2" SAE)	Each	2.0	\$0.26	\$0.52
Shop	Shop Supplies		1.0	\$17.50	\$17.50
Task 6 Subtotals				Parts:	\$178.09
				Labor:	\$250.00
				Miscellaneous:	\$17.50
				Task 6 Subtotals	\$445.59

Task: 7 004 Alignment 3 axle Department: Service

Complaint: Align
 Correction: 8/20/2022 9:45:48 AM 201 3 axle alignment

Supp. Part	Description / Ref Number	U/M	Quantity	Price	Extended Price
Shop	Shop Supplies		1.0	\$23.10	\$23.10
Task 7 Subtotals				Parts:	\$0.00
				Labor:	\$330.00
				Miscellaneous:	\$23.10
				Task 7 Subtotals	\$353.10

Detail Tax Info:

Sales Tax	\$56.13
Total:	\$56.13

Total Parts:	\$680.34
Total Labor:	\$1,142.51
Total Miscellaneous:	\$100.09

** See Last Page for Invoice Total **



875 East South Loop
 P.O. Box 1947
 Stephenville, TX 76401
 Ph: (254) 965-4403
 www.txtrucksdirect.com

**** Reprint ****
 Invoice: **01S119078**
 Date / Hour: 8/22/2022 11:18:03AM
 Repair Order: 119078
 Customer: 1725
 Branch: 01
 Total Invoice: \$ 1,979.07
 Check - 40551
 Page 1 of 3

Bill To: Hamilton Pipe
 Thank You For Your Business!
 Come Back Again!
 Stephenville, TX 76401

Ship To: Hamilton Pipe
 , TX

Customer P/O: . mbishop Karmak Orig R/O: 0 Completion Date: 08/20/2022

Unit Number: 121311 **Model Year: 2011** **Make/Model: Peterbilt 379**
Type: service **VIN: 1XP7D49X0BD121311** **Meter: 638551 Miles**

Task: 1 009 Pre-Repair Inspection **Department: Service**
 Complaint: inspect and advice
 Correction: 8/18/2022 2:25:49 PM 201 pre repair inspection see pre repair sheet

Supp.	Part	Description / Ref Number	U/M	Quantity	Price	Extended Price
Task 1 Subtotals						(\$0.01)

Task: 2 010 Test Drive **Department: Service**
 Complaint: advice

Supp.	Part	Description / Ref Number	U/M	Quantity	Price	Extended Price
Task 2 Subtotals						\$0.00
					Labor:	\$62.50
Task 2 Subtotals						\$62.50

Task: 3 006 Prealignment Inspection **Department: Service**
 Complaint: front end alignment, has a shimmy around 40/45mph.
 Correction: 8/18/2022 2:47:38 PM 201 Pre alignment inspection:
 The only things I found bad are the torque arms over the top of rear differentials.
 The kingpins were good.
 The shackle pins and bushings are good.
 The tie rod ends are good and the drag link is good.
 The rear suspension bushings are good; other than the two torque arms.

Supp.	Part	Description / Ref Number	U/M	Quantity	Price	Extended Price
	Shop	Shop Supplies		1.0	\$8.75	\$8.75
Task 3 Subtotals						\$0.00
					Labor:	\$125.00
					Miscellaneous:	\$8.75
Task 3 Subtotals						\$133.75

Task: 4 049 R & R Torque Arm **Department: Service**
 Complaint: Replace 2 torque arm
 Correction: 8/20/2022 8:20:54 AM 201 R&R both torque arms over the top of differentials

Supp.	Part	Description / Ref Number	U/M	Quantity	Price	Extended Price
	83-6029-3	Nylon Tie (15-1/4" Black)	Each	6.0	\$0.21	\$1.26
	TMR553	Torque Rod (Peterbilt)	Each	2.0	\$135.22	\$270.44
	Freight	Freight		1.0	\$24.50	\$24.50
	Shop	Shop Supplies		1.0	\$17.50	\$17.50
Task 4 Subtotals						\$271.70
					Labor:	\$250.00
					Miscellaneous:	\$42.00
Task 4 Subtotals						\$563.70

Task: 5 013 R & R Brake Drum (Rear Outboard, Each) **Department: Service**
 Complaint: Left rear brake drum replace

** See Last Page for Invoice Total **



MHC KENWORTH - WACO
 3331 GREIG DRIVE
 ROBINSON, TX 76706
 1-254-662-2100

CASH RECEIPT



Payment Type	Taken By	Customer #	Reference #	Date
REPAIR ORDER	BRITTANY RHOUES	0184263	R00623700206433	12/31/2022

Hamilton Pipe Company
 1088 W Highway 36
 Hamilton TX 76531-2020
 (254) 386-5710

Type	Amount	Authorization #	Number
CHECK	1,875.14	681429	40853

TRK
Repair

CASH	1,875.14
CHECK	
CREDIT CARD	
CREDIT MEMO	
DEPOSIT	
Total Payment Amount	1,875.14

TERMS AND CONDITIONS OF THIS SALE ARE SET FORTH BELOW AND THOSE CONTAINED AT WWW.MHC.COM/DEALERS/TERMS.HTM WHICH ARE INCORPORATED HEREIN BY THIS REFERENCE

- PAYMENT:** Customer shall pay Dealer the total amount listed on the Order, which shall be due in cash upon the tender by Dealer to Customer of the Parts, unless and until credit terms for Customer are approved in a writing signed by a corporate officer or authorized manager of the Dealer. For Customers whose credit has been duly approved in advance by Dealer in a writing signed by a corporate officer or authorized manager of Dealer, the amounts due to Dealer for the Parts shall be in accordance with the terms of the Credit Agreement executed by Customer in connection with applying for credit with Dealer. The terms and provisions of any such Credit Agreement signed by Customer are incorporated herein. An interest charge of 1.5% per month will be charged on past due balances.
- ARBITRATION:** Any controversy or claim arising out of or relating to the Order shall be decided by arbitration administered by the American Arbitration Association in accordance with its Commercial Arbitration Rules, subject to the limitations and restrictions as set forth in the Terms and Conditions contained at www.mhctruck.com/dealers/terms.

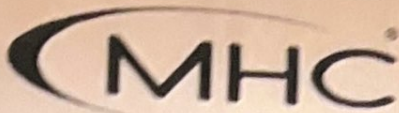

125+ Locations in 18 states. mhc.com

SERVICING DEALERSHIP

TEXAS KENWORTH CO. LLC, DBA

MHC KENWORTH - WACO
3331 GREIG DRIVE
ROBINSON, TX 76706
1-254-662-2100

REPAIR ORDER

Customer Number: 184263	Phone: (254) 386-5710	Invoice Number: R00623700206433
-------------------------	-----------------------	---------------------------------

- * MHC IS CERTIFIED FOR CATERPILLAR, CUMMINS AND MX *
- * OVERHAULS/WARRANTY REPAIRS *
- * MHC OFFERS PARTS AND SERVICE FOR ALL MAKES OF TRUCK *

REPAIR ORDER SUMMARY	AMOUNT
Labor Total	900.00
Parts Total	789.11
Shop Supplies	108.00
Sales Tax	73.03
Machine Charge	5.00

TOTAL DUE 1,875.14

REMIT TO:
P.O. BOX 879269
KANSAS CITY, MO 64187-9269



TERMS AND CONDITIONS OF THIS SALE ARE SET FORTH BELOW AND THOSE CONTAINED AT <https://mhc.com/terms-and-conditions> WHICH ARE INCORPORATED HEREIN BY THIS REFERENCE.

1. **PAYMENT:** Customer shall pay Dealer the total amount listed on the order, which shall be due in cash upon the tender by Dealer to Customer of the Parts, unless and until credit terms for Customer are approved in a writing signed by a corporate officer or authorized manager of the Dealer. For Customers whose credit has been duly approved in advance by Dealer in a writing signed by a corporate officer or authorized manager of Dealer, the amounts due to Dealer for the Parts shall be in accordance with the terms of the Credit Agreement executed by Customer in connection with applying for credit with Dealer. The terms and provisions of any such Credit Agreement signed by Customer are incorporated herein. An interest charge of 1.5% per month will be charged on past due balances.

2. **ARBITRATION:** Any controversy or claim arising out of or relating to the Order shall be decided by arbitration administered by the American Arbitration Association in accordance with its Commercial Arbitration Rules, subject to the limitations and restrictions as set forth in the Terms and Conditions contained at <https://mhc.com/terms-and-conditions>.

MHC250RD 1/22



120+ Locations in 19 states, mhc.com

SERVICING DEALERSHIP

TEXAS KENWORTH CO, LLC, DBA

MHC KENWORTH - WACO
3331 GREIG DRIVE
ROBINSON, TX 76706
1-254-662-2100

REPAIR ORDER

Customer Number: 184263	Phone: (254) 386-5710	Invoice Number: R00623700206433
-------------------------	-----------------------	---------------------------------

- * MHC IS CERTIFIED FOR CATERPILLAR, CUMMINS AND MX *
- * OVERHAULS/WARRANTY REPAIRS *
- * MHC OFFERS PARTS AND SERVICE FOR ALL MAKES OF TRUCK *

REPAIR ORDER SUMMARY	AMOUNT
Labor Total	900.00
Parts Total	789.11
Shop Supplies	108.00
Sales Tax	73.03
Machine Charge	5.00

TOTAL DUE 1,875.14

REMIT TO:
P.O. BOX 879269
KANSAS CITY, MO 64187-9269



TERMS AND CONDITIONS OF THIS SALE ARE SET FORTH BELOW AND THOSE CONTAINED AT <http://mhc.com/terms-and-conditions> WHICH ARE INCORPORATED HEREIN BY THIS REFERENCE.

1. **PAYMENT:** Customer shall pay Dealer the total amount listed on the order, which shall be due in cash upon the tender by Dealer to Customer of the Parts, unless and until credit terms for Customer are approved in a writing signed by a corporate officer or authorized manager of the Dealer. For Customers whose credit has been duly approved in advance by Dealer in a writing signed by a corporate officer or authorized manager of Dealer, the amount due to Dealer for the Parts shall be in accordance with the terms of the Credit Agreement executed by Customer in connection with applying for credit with Dealer. The terms and provisions of any such Credit Agreement signed by Customer are incorporated herein. An interest charge of 1.5% per month will be charged on past due balances.
2. **ARBITRATION:** Any controversy or claim arising out of or relating to the Order shall be decided by arbitration administered by the American Arbitration Association in accordance with its Commercial Arbitration Rules, subject to the limitations and restrictions as set forth in the Terms and Conditions contained at <http://mhc.com/terms-and-conditions>

MHC250RO 02